



# Print and Apply Solutions

## Applicator Selection Guide

**MECTEC**

# The unknown art of applying a label . . .

2

One might think that applying a label is one of the easiest things you could do.

- We know better than that . . . !

For 20 years we have been devoted to supplying the optimal Print & Apply solutions to the market.

Early - we found out that applying a label many times can be quite "tricky" and that there is more to consider than one might think . . .

Product speed, label size, shape, surface, operator handling, side to be labelled, environment . . .

The list of different factors that you MUST consider if you want a good solution that will last for many years

- can be made long.

When choosing Mectec for your project - you can be confident that we have the knowledge to get all the essential facts

- that will assure you having the best possible solution to your Print & Apply application !

This brochure as a short guide and example of what can be done - and what will have to be considered to achieve it !

## 4 basic ways to apply the label



### Blow

*Fast, easy and cheap  
Very limited distance  
Not so accurate*

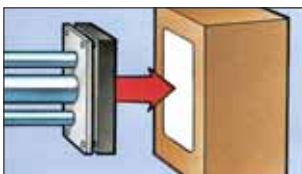

### Tamp

*Most common  
Fits most applications  
Flexible distance, accurate*

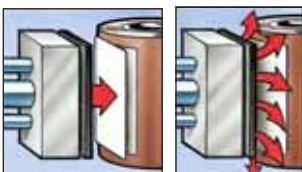

### Tamp and Blow

*Air Blow helps label stick  
also on uneven surfaces*

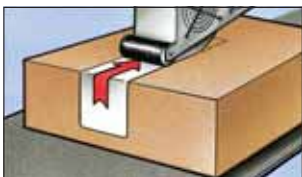

### Wipe

*The best way to apply  
long labels*

## Label size and direction

Size of label is always in respect to the Print direction. You always mention the width and the length. Example: A5 portrait label is 148 (w) x 210 (l) mm.

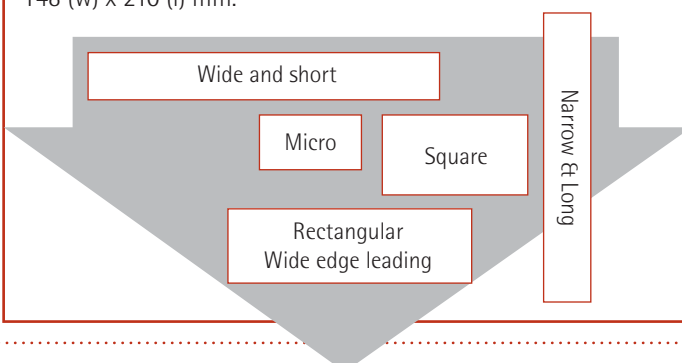

## Where to apply the label



A - Side



B - Top



C - Front



D - Back

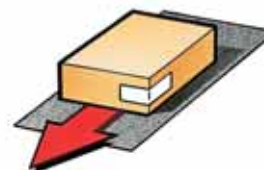

E - Front-Side (Corner)



F - Side-Back (Corner)



G - Front and Side

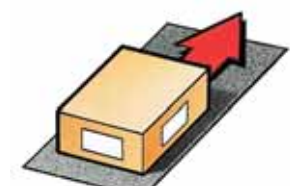

H - Side and Back

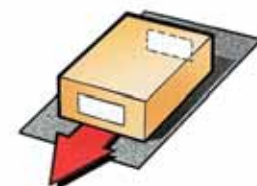

I - Front and Back

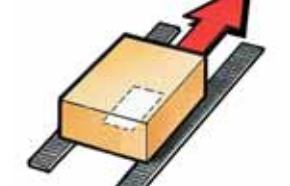

J - Bottom

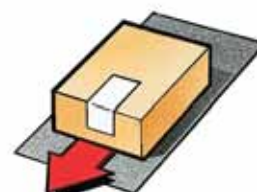

K - Front-Top (Wrap)



L - Top-Back

## The DISTANCE to the object

The distance to the object is important. The shorter - the better! 200 - 300 mm is very typical - but up to over 1 meter is possible (can be divided onto two or three cylinders).

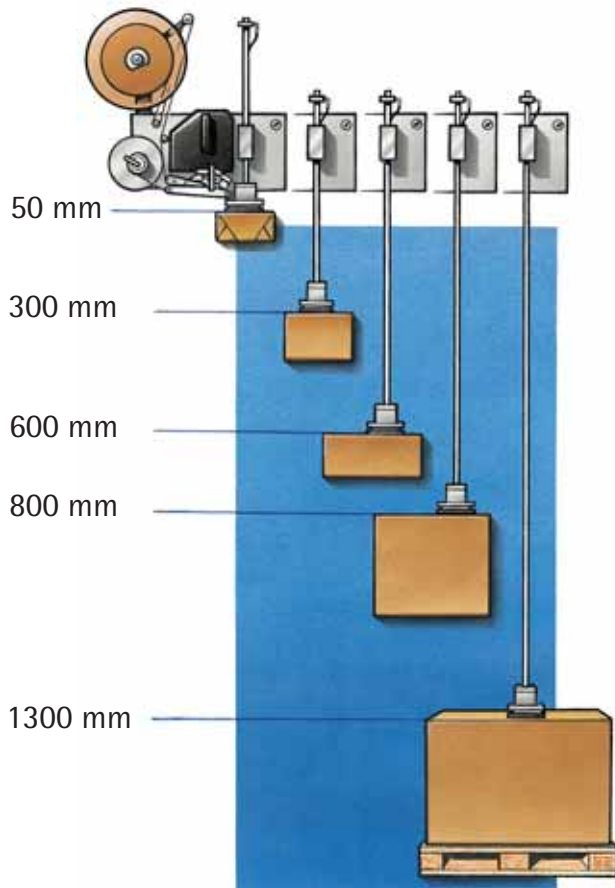

## The SHAPE of the object

In perhaps 80 % of the cases you have an even regular object/surface. For some cases it might however be more "tricky" and special considerations have to be made.

- A** For fragile and/or odd-shaped objects - BLOW on is best
- B** For convex objects like tubes, paper rolls etc - a concave press-on pad with built in air blow helps do the job.
- C** For concave objects - a convex press-on pad with built in air blow gets the label applied.
- D** For rugged surfaces like wood/pallets etc - a press-on pad with rubber coating makes the label stick.

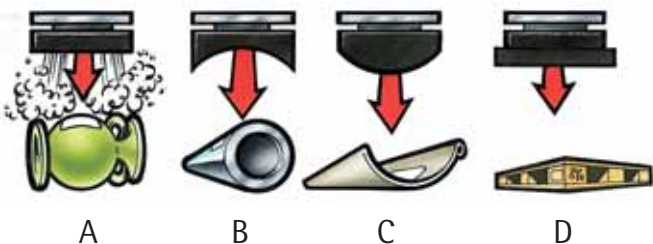

## Operation and Mounting

To optimize handling, performance and operation - all machines are available in both LEFT and RIGHT hand versions. Furthermore, they are designed so that they can be mounted in many different ways.

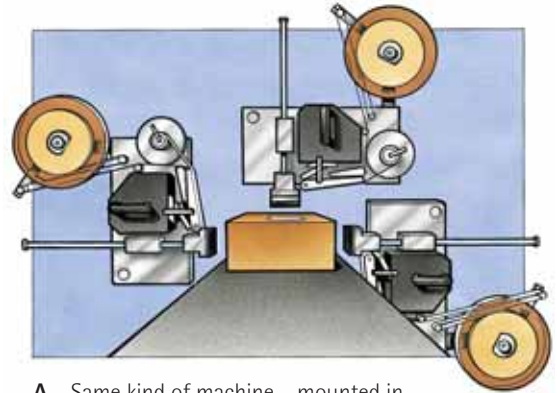

**A** - Same kind of machine - mounted in different ways. Top-Down or Side-In

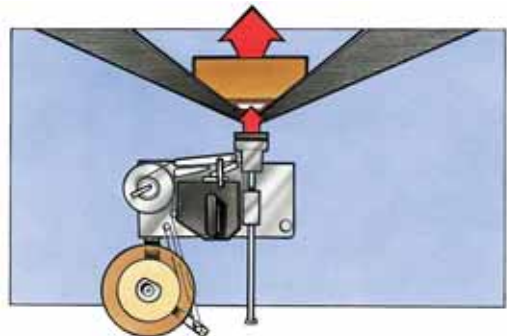

**B** - Also working from underneath - Bottom-Up - is possible

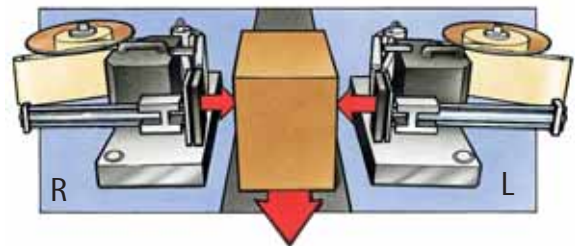

**C** - Right hand and Left hand machines laying down on side - printing in the same direction as object is moving

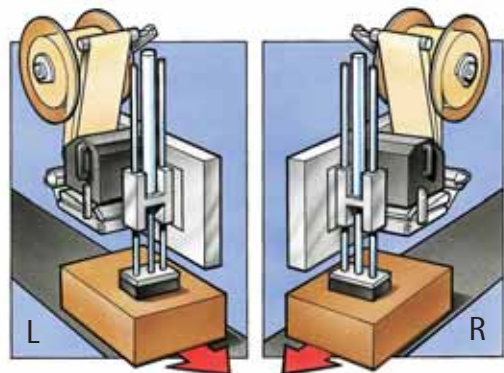

**D** - Left hand and Right hand machines working Top-Down

## Mectec's wide product range . . .

We are proud to offer you the market's widest range of products and solutions within Print & Apply. With twelve models of print engines and 60+ different applicator solutions - you are sure to get exactly the solution that fits and solves Your application in the best possible way !

Below you will find an overview of the most common variants / groups of applicator solutions. For further details and additional models / solutions - contact your sales representative.

### A 1160

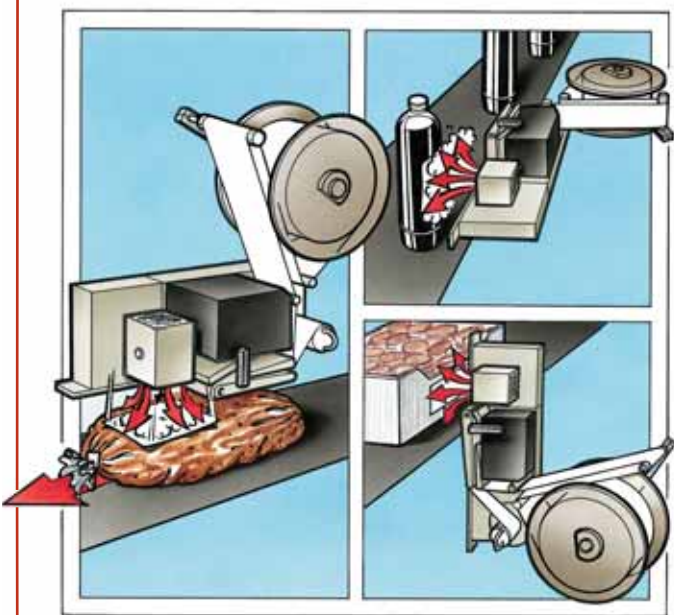

**Apply where:** *Top/Bottom/Side*

**Distance:** *0-50 mm*

**Recommended Label Size:** *Min 40x40 Max 100x100*

**Information:** *Adjustable blow*

### A 1170

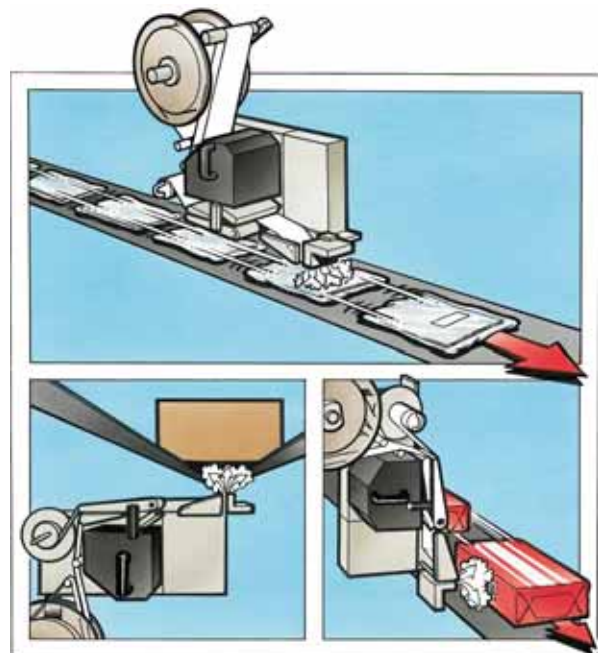

**Apply where:** *Top/Bottom/Side*

**Distance:** *0-50 mm*

**Recommended Label Size:** *Min 20x20 Max 100x50*

**Information:** *Adjustable beak. NOT 1:1 print/apply*

### A 2170

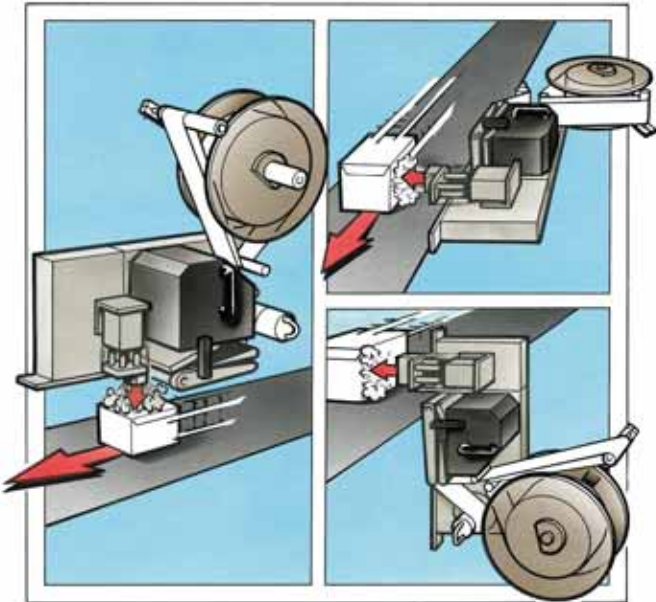

Apply where: *Top/Bottom/Side*

Distance: *Approx. 50 mm*

Recommended Label Size: *Min 20x20 Max 100x50*

Information: *Blow On with better accuracy*

### A 2220

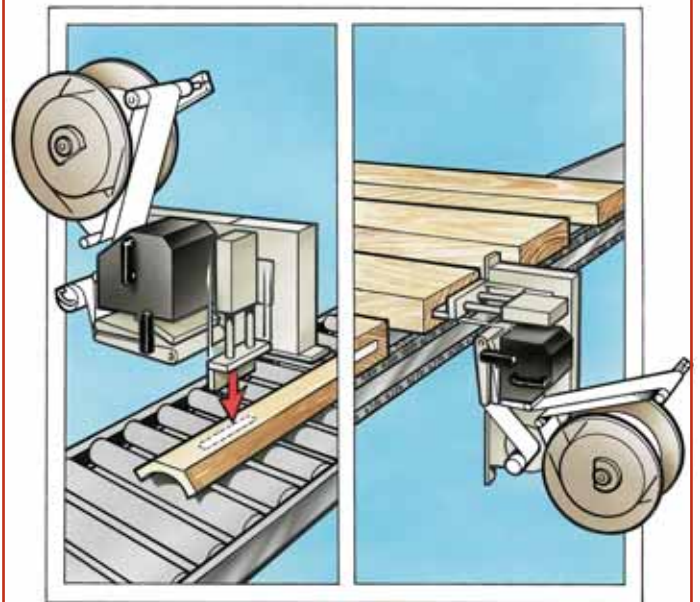

Apply where: *Top/Bottom/Side*

Distance: *0-1000 mm*

Recommended Label Size: *Min 20x20 Max 210x160*

Information: *Small and medium size label*

### A 2225

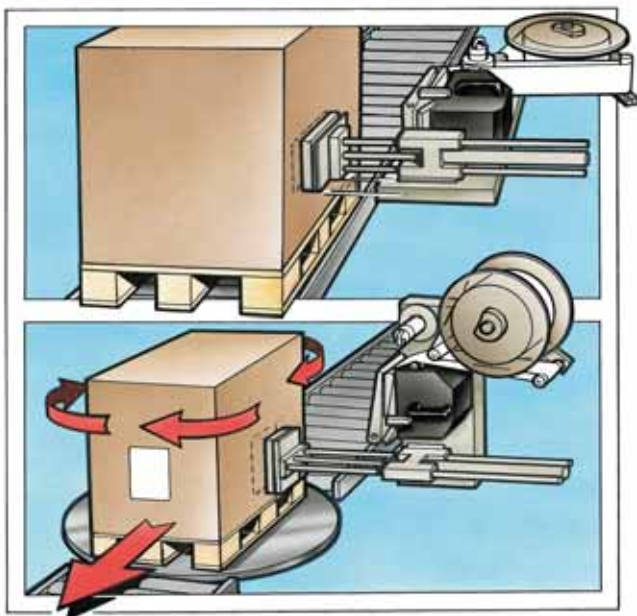

Apply where: *Top/Bottom/Side*

Distance: *0-1000 mm*

Recommended Label Size: *Min 50x165 Max 210x300*

Information: *Large size labels*

### A 2240

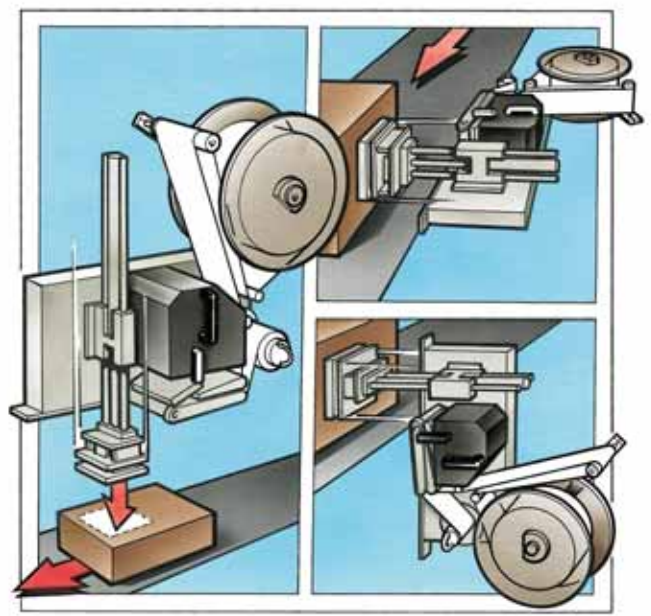

Apply where: *Top/Bottom/Side*

Distance: *0-1000 mm*

Recommended Label Size: *Min 40x40 Max 210x160*

Information: *For labelling in dusty environments*

## A 2335M / A 2335M + M512

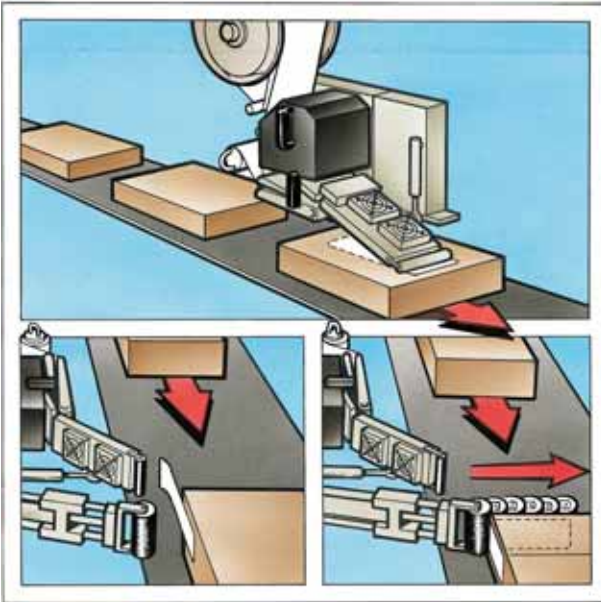

Apply where: *Top/Bottom/Side or around a corner*

Distance: *0-70 mm*

Recommended Label Size: *Min 50x200 Max 160x350*

Information: *Side - back / Top - back with pusher*

## A 3225

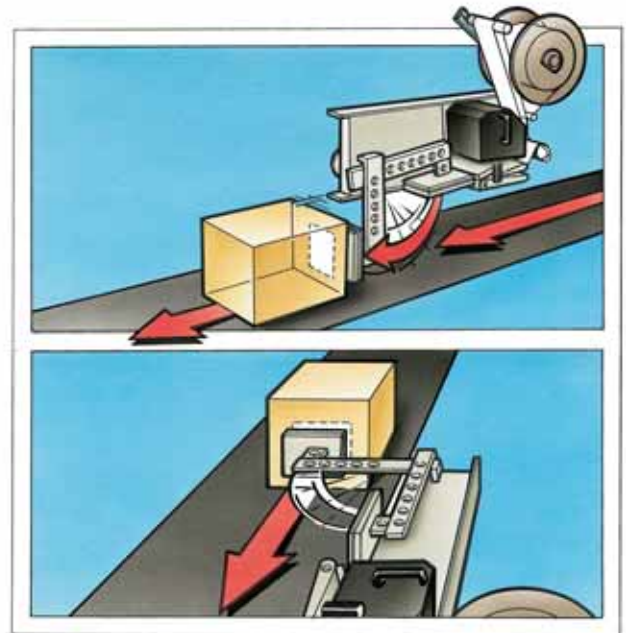

Apply where: *Front or Back*

Distance: *0-400 mm*

Recommended Label Size: *Min 20x20 Max 160x250*

Information: *The label is applied on a moving product*

## A 2385M

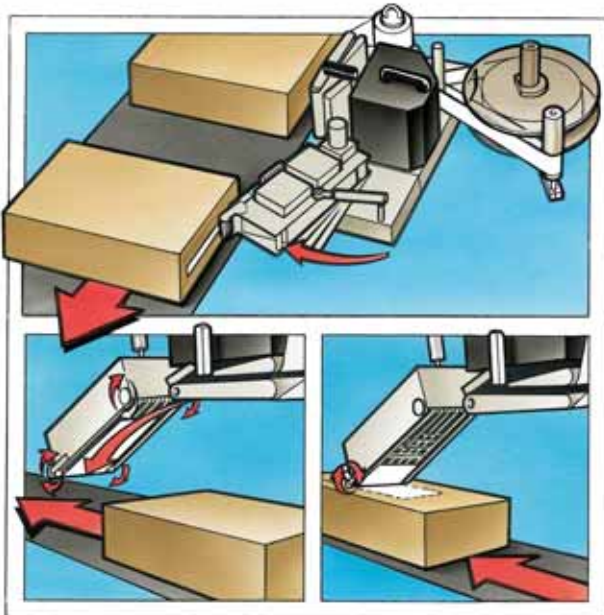

Apply where: *Top/Bottom/Side or around a corner*

Distance: *0-70 mm*

Recommended Label Size: *Min 30x100 Max 160x500*

Information: *Side - back / Top - back with pusher*

## A 8210

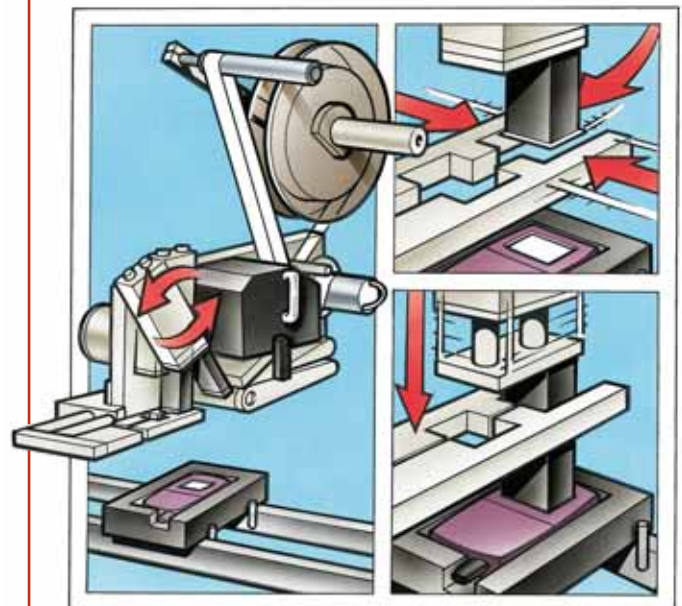

Apply where: *Top/Bottom/Side*

Distance: *0-100 mm*

Recommended Label Size: *Min 5x5 Max 60x80*

Information: *The label are applied with a very high accuracy,  $\pm 0,1\text{mm}$*

## Handling Options for Pallet Labellers

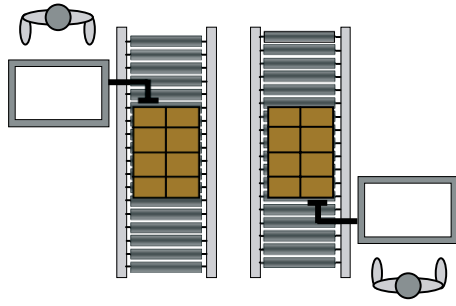

Left hand / Turning inwards (TI)

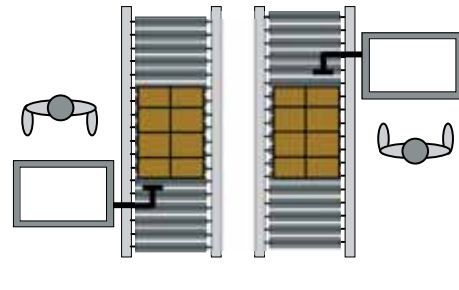

Left hand / Turning outwards (TO)

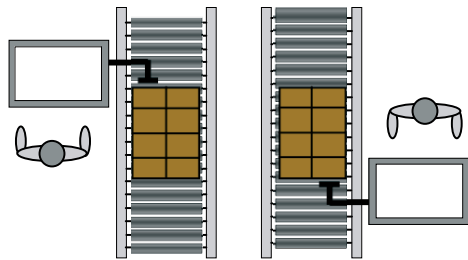

Right hand / Turning outwards (TO)

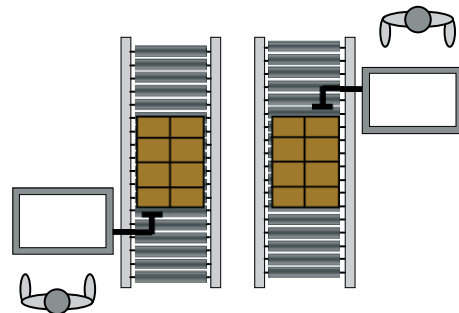

Right hand / Turning inwards (TI)

### A 6225 - TI Ø

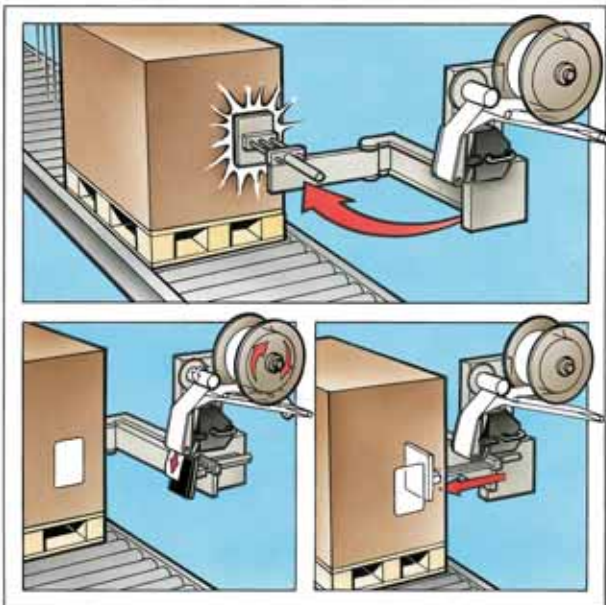

Apply where: *Front and Side*

Distance: *Approx. 200 mm*

Recommended Label Size: *Min 50x50 Max 160x250*

Information: *The labels are applied on a moving pallet/carton*

### A 6225 - TI 2 (A 6220 - TI 1)

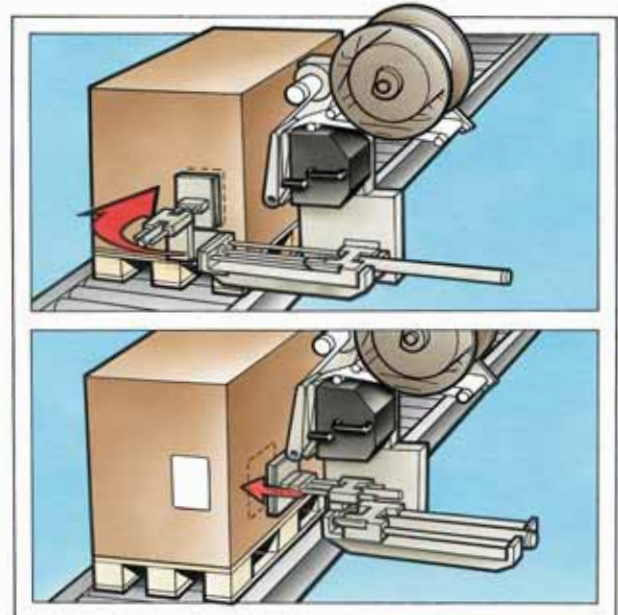

Apply where: *Front and Side / Side and Back*

Distance: *0-800 mm*

Recommended Label Size: *Min 50x50 Max 160x250*

Information: *One or two stops to apply the labels*



## Mectec around the world

# MECTEC

---

Mectec Elektronik AB | Agnesfridsvägen 189 | SE-213 75 Malmö

Phone: +46 (0)40 689 25 00 | Fax: +46 (0)40 689 25 25 | [info@mectec.se](mailto:info@mectec.se) | [www.mectec.com](http://www.mectec.com)